

■Features

- High Luminous LEDs
- 3mm Round Standard Directivity
- Long Lifetime Operation
- UV Resistant Epoxy/ White Diffused Type
- Bi-Color AC LED

■Applications

- Toys
- Audio
- Games
- Other Lighting

■Outline Dimension

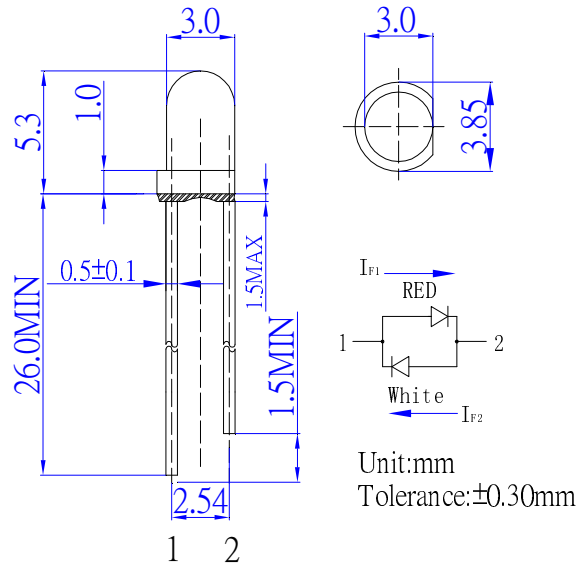

■Absolute Maximum Rating

(Ta=25°C)

Item	Symbol	Value		Unit
		Red	White	
DC Forward Current	I _F	30	30	mA
Pulse Forward Current#	I _{FP}	100	100	mA
Reverse Voltage	V _R	5	5	V
Power Dissipation	P _D	78	108	mW
Operating Temperature	T _{opr}	-30 ~ +85		°C
Storage Temperature	T _{stg}	-40 ~ +100		°C
Lead Soldering Temperature	T _{sol}	260°C/5sec		-

#Pulse width Max.10ms Duty ratio max 1/10

■Directivity

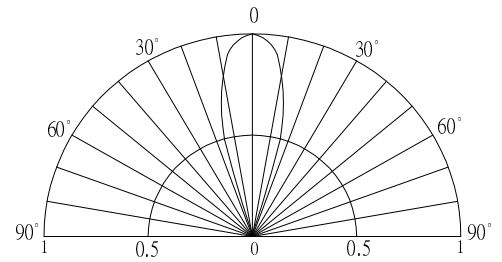

■Electrical -Optical Characteristics

(Ta=25°C)

Item	NO.	Symbol	Condition	Min.	Typ.	Max.	Unit
DC Forward Voltage*	RED	V _{F1}	I _{F1} =20mA	1.8	2.1	2.6	V
	White	V _{F2}	I _{F2} =20mA	2.9	3.1	3.6	V
Domi. Wavelength*	RED	λ _{D1}	I _{F1} =20mA	620	625	630	nm
	White	CCT	I _{F2} =20mA	3000K		-	-
Luminous Intensity*	RED	I _{V1}	I _{F1} =20mA	100	150	-	mcd
	White	I _{V2}	I _{F2} =20mA	330	500	-	mcd
50% Power Angle	RED	2θ _{1/2}	I _{F1} =20mA	-	30	-	deg
	White	2θ _{1/2}	I _{F2} =20mA	-	30	-	deg

*1 Tolerance of measurements of chromaticity coordinate is ±10%

*2 Tolerance of measurements of dominant wavelength is ±1nm

*3 Tolerance of measurements of luminous intensity is ±15%

*4 Tolerance of measurements of forward voltage is ±0.1V